

И.Маннопова, Р. Мавлонова, Н. Ибрагимова

ТЕХНОЛОГИЯ

Китоби дарсӣ барои синфҳои 1-уми мактабҳои таълими
миёнаи умумӣ

Нашри панҷуми такмилёфта

Вазорати Таълими халқи Республикаи Ўзбекистон тасдиқ
намудааст

ХОНАИ ЭҶОДИИ ТАБЪУ НАШРИ “O‘QITUVCHI”
ТОШКАНД – 2019

УЎК: 373.3.016:331(075.2)
КБК 74.200.52
М 21

Тақризчилар:

- З. Шамсиева** – Мудир шўъбаи Маркази таълими республика;
М. Пўлатова – Омўзгори фанни технологияи мактаби таълими миёнаи умумии 144-уми шаҳри Тошкент;
Д.Каримова – Омўзгори фанни технологияи мактаби таълими миёнаи умумии 18-уми шаҳри Бухоро;

Аломатҳои шартӣ:



– омўзгор меҳонад;



– дар гурӯҳ кор мекунем;



– кори амалӣ;



– фикр мекунем, ҷавоб медиҳем;



– бо кўмаки падару модар тайёр мекунем;



– кори эҷодӣ.

Аз ҳисоби маблағҳои Бунёди мақсадноки китоби республика чоп шудааст.

ISBN 978-9943-22-346-2

© И. Маннопова ва диг.
© ХЭТН «O'qituvchi», 2019

Дарси 1. МАФҲУМ ДАР БОРАИ ФАННИ ТЕХНОЛОГИЯ



Ба расм бо диққат назар андозед!



Яке аз кӯчаҳои шаҳр нишон дода шудааст. Дар расм чӣҳоро мебинед?

Аз расм чизҳои табиӣ ва аз ҷониби инсон сохташударо ёбед ва номбар кунед.

ОЛАМЕ, КИ ИНСОН БУНЁД КАРДААСТ



 Оё ҷиҳозҳои дар ин хона буда, барои мо заруранд? Онҳоро кӣ сохтааст? Аз кадом маҳсулот тайёр шудаанд?



Ҷиҳозҳои дар расмҳо тасвиршуда аз кадом маҳсулот тайёр шудааст? Барои тайёр кардани онҳо инсон аз чӣ истифода бурдааст?

 Ба расм эътибор диҳед. Соҳиб-касбони дар он тасвиршуда кадом корхоро ба иҷро расонида истодаанд? Касби онҳоро номбар кунед.



Асбобҳои барои ҳар як соҳибкасб заруриро интихоб кунед.



 Фанни технология усулҳои корро бо маводи додашуда меомӯзад.



ҚОИДАҲОИ ТЕХНИКАИ БЕХАТАРӢ

ҚОИДАИ КОР БО ҚАЙЧӢ

Соҳти қайчӢ чӢ гуна аст?

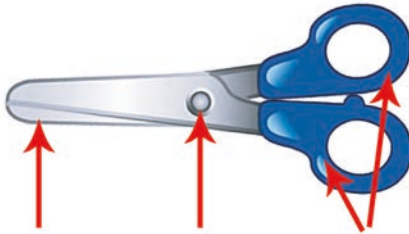

Теғ Мехи печӢ Ҳалқа



Ба расм эътибор диҳед. Чаро қайчиро чунин дароз мекунанд?



Шумо чӢ фикр доред? Чаро қайчиро дар ғилоф нигоҳ ме-доранд?

Бо қайчӢ аз коғази дарозшакл секунҷа ва квадрат буред.



Мизи корӢ





Қоидаи қор бо ширеш

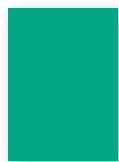

Ширешро аз миёна ба қанор молад.



Ширеши зиёдати ро пок қарда ги-ред. Ба боляш қизеро гузошта хушк қунед.



Баъди истифода бурдани мўйқалам, онро шуста қонед. Зарфи ширешдорро дар ҳолати пўшида нигоҳ қоред.



Дарси 2. СОХТАНИ МАНЗАРАИ „ТИРАМОҶИ ЗАРРИН“

Табиат рангоранг ва зебост. Инсон низ офарандагиро доимо аз табиат меомӯзад.



Аҳамият диҳед, ки аз маводҳои табиӣ зебогии табиатро чӣ гуна офаридан мумкин аст? Барои ин аз кадом маводҳои табиӣ истифода мебаранд.



Фикр карда бинед. Чаро табиатро бояд ҳимоя кард?



КОР БО БАРГ

Баргҳоро чӣ гуна бояд хушк кард?

Баргҳои рехтаро чинда гиред.



Ба боляш ягон чизро гузошта хушк кунед.



Тартиби дар расм нишондодашударо риоя карда, бо барг кор кунед.





ҲОСИЛ КАРДАНИ МАНЗАРАИ ТИРАМОҶИ ЗАРРИН АЗ БАРГ



Мустақилона аз барг манзараи
тирамоҷи зарринро созед.





Дарси 3. СОХТАНИ КОМПОЗИТСИЯИ НАҚШ АЗ БАРГҲО

Дар расм аз баргҳо композитсияи нақш дода шудааст. Муқоиса кунед. Кадоме аз онҳо ба шумо маъқул аст? Чаро?



Композитсия – тасвирҳоро нисбат ба ҳамдигар бо тартиби муайян ҷой додан.





Барои сохтани нақш баргҳоро интихоб карда гиред. Онҳоро чӣ гуна ҷойгир кардан мумкин аст? Фикр карда бинед.

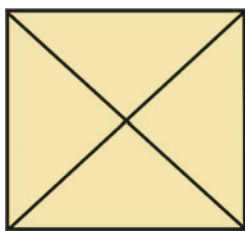

1



2



3



4



1



2



3

Дар хотир доред! Баргро бо қайчӣ набуред, аз онҳо шаклҳои заруриашро интихоб кунед. Ҳангоми часпонидан ширешро ба рағчаҳои барг молед. Баъди иҷрои кор ба болояш ягон чиз гузошта хушк кунед.



Дарси 4. СОХТАНИ ШАКЛИ ПАРРАНДАҲО АЗ БАРГ



1



2



3



4



5



6

Мустақилона созед.





АЗ МАВОДҶОИ ТАБИЙ СОХ- ТАНИ ШАКЛИ ПАРРАНДА



1



2



3



4



5



Дарси 5. СОХТАНИ ШАКЛИ ҶАЙВОНОТ АЗ БАРГ

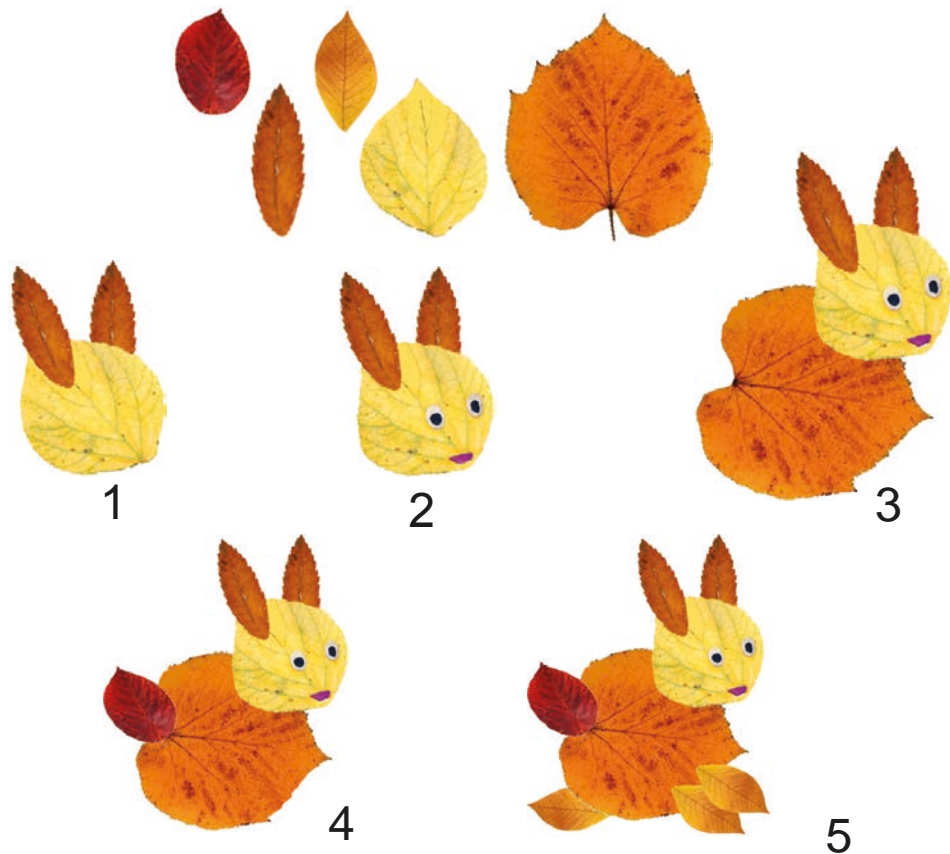

Дар сурат чӣ тасвир шудааст? Он аз кадом қисмҳо иборат? Барои кашидани харгӯш ба шумо чӣ гуна баргҳо лозим мешаванд? Пайдарҳамии корро аз назар гузаронед ва мустақилона созед.



МУҚОИСА КУНЕД





Дарси 6. СОХТАНИ ПАРРАН-ДАҶО АЗ БАРГ



1



2



3



1



2



3



4



Дарси 7. СОХТАНИ ПАРРАН- ДАҲО АЗ МАВОДҲОИ ТАБИЙ ВА СУНЪЙ



1



2



3



4

Мустақилона созед.

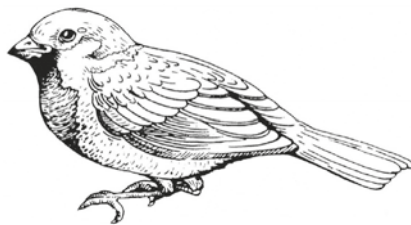



Дарси 8. СОХТАНИ КОМПОЗИТСИЯ АЗ МАВОДҲОИ ТАБИЙ ВА СУНЪЙ



Растаниҳо як қисми табиатро ташкил медиҳанд. Барои кори эҷодии усто ва рассомон табиат маводҳои гуногун медиҳад. Ба кори рассом ва устоҳо табиат чӣ гуна мавод медиҳад? Гуфта диҳед.



Диққат. Шоху баргҳоро аз дарахтон нақанед ва нашиканед. Танҳо баргҳои ба замин афтидаро бардоред. Табиатро эҳтиёт намоед!



Дарси 9. ҶАМЪ КАРДАН ВА НИГОҶ ДОШТАНИ ТУХМӢ



Дар баҳор ва тирамоҳ растаниҳо тухмӣ ҳосил мекунанд. Муайян кунед, ки тухмиҳои дар расм додашуда аз кадом растанӣ аст.



Дар хотир доред! Ҷангоми ба сайру гашт баромадан, тухмиҳоро ҷамъ карда оед ва нағзакак шуста, хушк кунед. Баъд онҳоро дар зарфҳо нигоҳ доред.



Дарси 10. СОХТАНИ НАҚШ АЗ ТУХМӢ



Аз картони ранга росткунҷае бурида гиред, ки бараш 3 см ва баландиаш 9 см бошад. Бо қалам ба қисмҳои баробар тақсим кунед. Ба дарунаш ягон нақшо кашида бо пластилин ё ширеш тухмиҳоро ба нақш часпонед.

1



2



3



4





МУСТАҚИЛОНА СОЗЕД

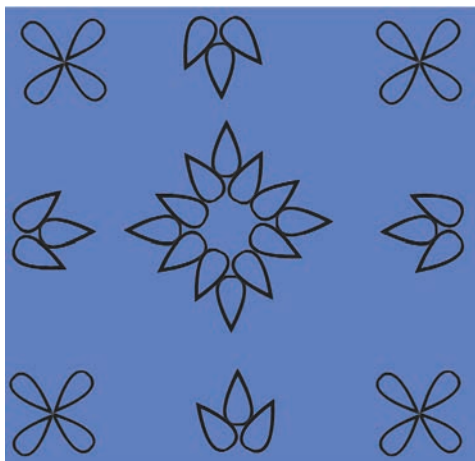
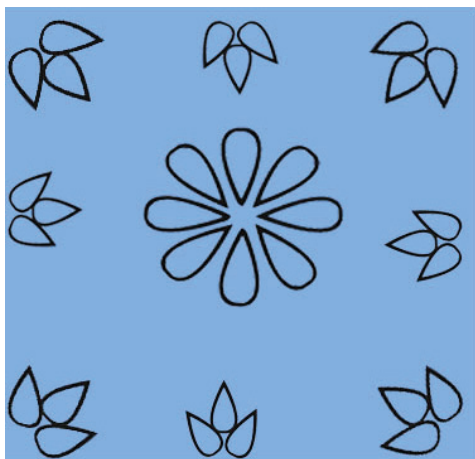



Дарси 11. СОХТАНИ ШАКЛИ МОҶИ



1

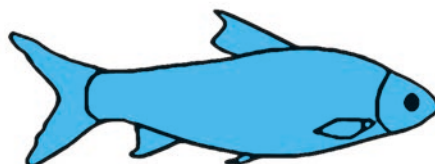

2

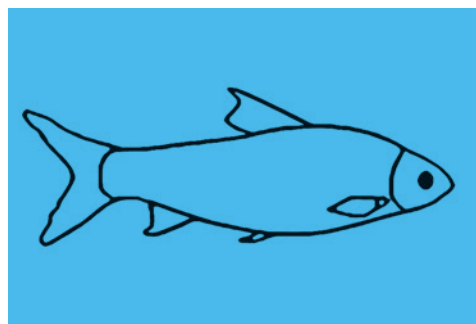

3

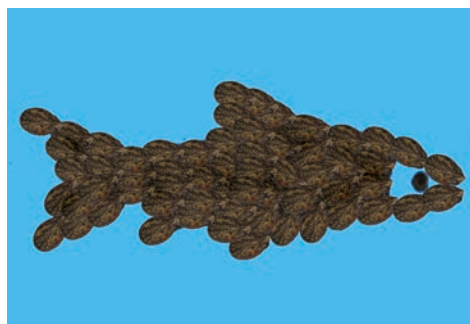

4

Мустақилона созад.

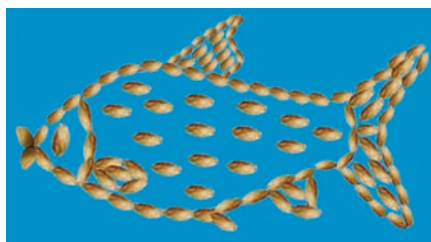



Дарси 12. СОХТАНИ ГУЛИ БОБУНА



1



2



3

Мустақилона созед.





ХУДРО БИСАНҶЕД



Омӯзгор ва падару модари худро хурсанд намоед. Нишон диҳед, ки чиро аз худ кардед ва чиро сохта метавонед. Ҷавоби дурустро интихоб намоед.

Ҳангоми кор бо маводҳои табиӣ кадом асбобҳоро истифода мебаред?



Маводҳои ғайритабиӣ чӣ гунаанд?



Дар кадом расм нақш дуруст сохта шудааст?



Бо ҳамсинфони худ ҷавобҳоро муҳокима кунед.



КОР БО КОҒАЗ ВА КАРТОН

Коғаз – маводест, ки ҳамеша ба мо лозим аст.



Шумо аз коғаз чиҳоро сохта метавонед? Ба расм бодикқат ни-гаред. Ин чизҳо ба кӣ ва барои чӣ заруранд?



Картонро аз байни коғазҳои ран-га ёбед. Чӣ монандӣ дорад? Ко-ғазҳои гуногунро истифода бурда бинед. Чиро мушоҳида кардед? Ху-сусиятҳои коғазҳоро номбар кунед.

Дарси 13. ҚОҒАЗ ВА НАМУДҲОИ ОН

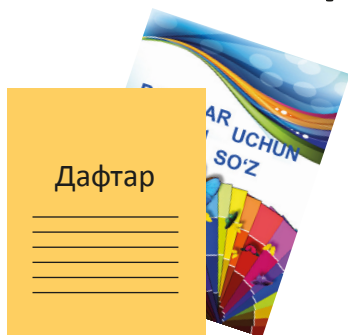

Қоғаз хатнависӣ



Қоғаз барои
чопи рӯзнома



Қартон



Қоғазии расмкашӣ



Ғулқоғазии тӯҳқарпечонӣ

КОР БО КОҒАЗ



Барои андоза нишона кардан.



Буридан.

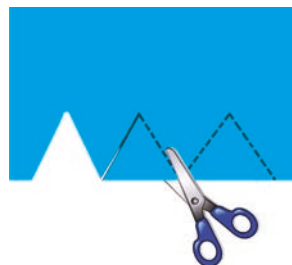

Бурида гирифтан.



Печонидан.

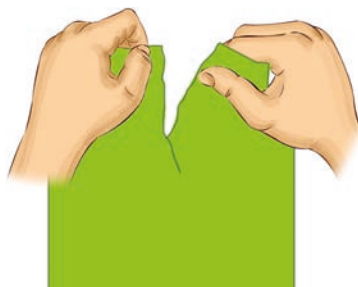

Даронидан.

Оё Шумо медонед, бо коғаз боз чӣ кор кардан мумкин аст?

УСУЛҲОИ ҚАТ КАРДАН ВА БУРИ- ДАНИ КОҒАЗ



Қат кунед.

Буред.



Қат кунед.

Буред.



Қат кунед.

Буред.



Қат кунед.

Печонед.



БОЗИИ УСТОИ ХУРДАКАК

Якҷоя зебой меофарем. Барои шумо инҳо заруранд.



Акнун шумо қоидаҳои корро бо қоғаз фаҳмида гирифтед. Барои сохтани чизҳо аз қоғаз аз онҳо истифода баред.



Аз варақи қоғаз чӣҳо ҳосил шуд?

Маҳорати худро кор фармуда, аз шаклҳои додашуда ягон намуд ҳосил кунед.

Расмҳои поёни ба чӣ монанданд?

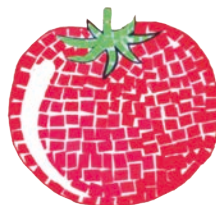



СОХТАНИ ХАРГҮШАК

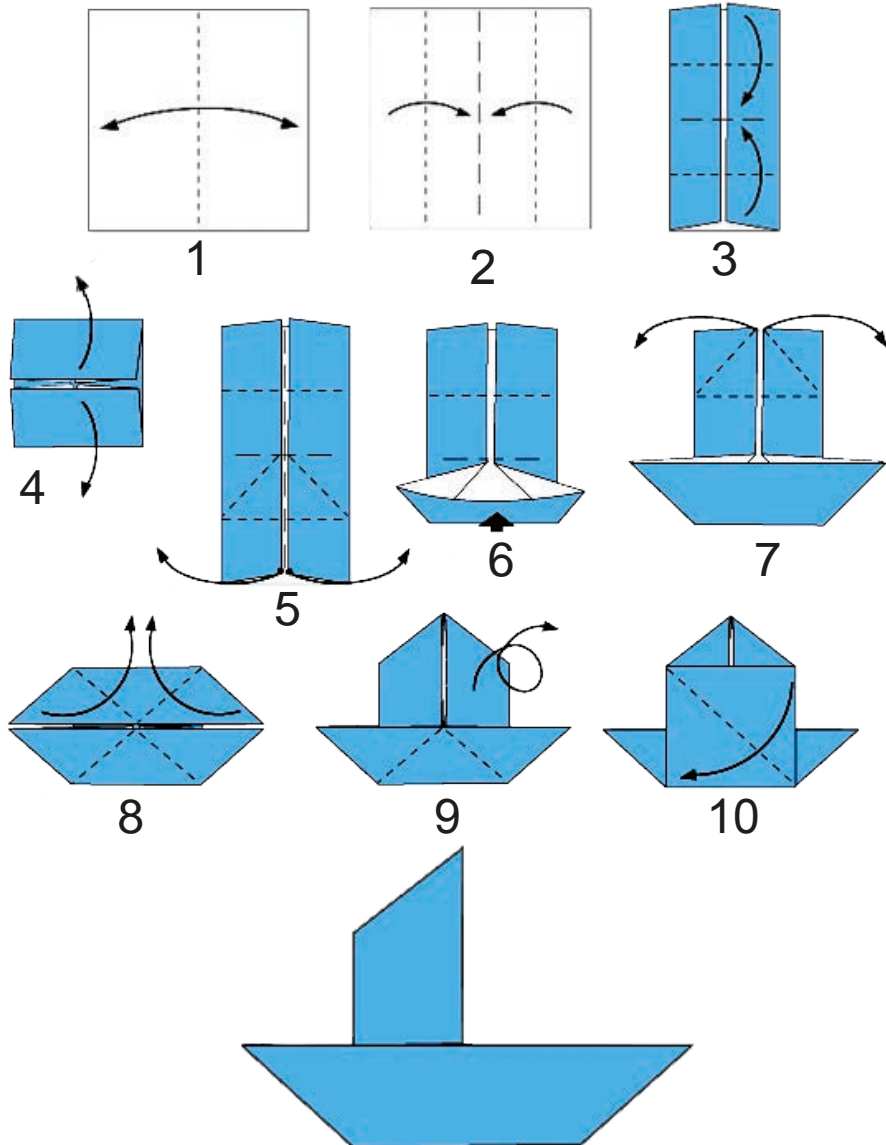



Дарси 14. СОХТАНИ ХАТЧҮБ БАРОИ КИТОБ

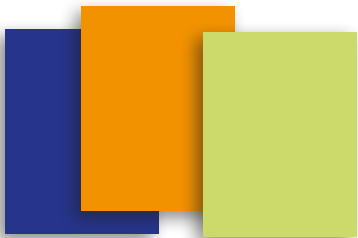

1





1

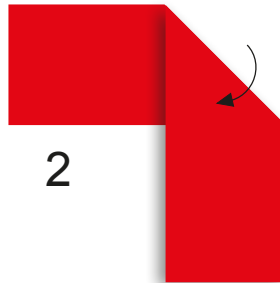

2

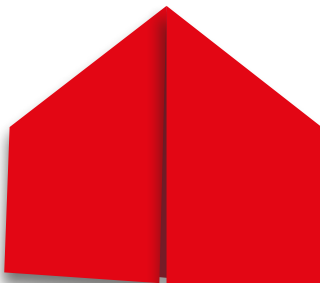

3

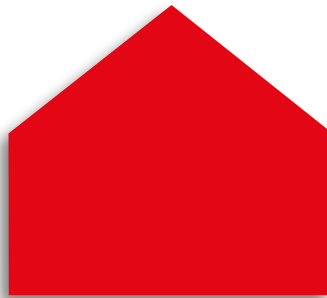

4

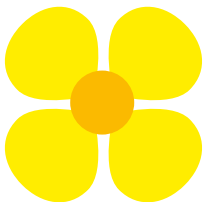

5



6



7

Хатчӯбро бо кадом мақсад истифода мебаранд?

Он барои шумо чӣ зарурат дорад?



Дарси 15. СОХТАНИ САГЧА АЗ КОҶАЗ

Дар асоси санъати техникаи қат кардани коғаз сохтани шаклҳоро **оригами** меноманд.

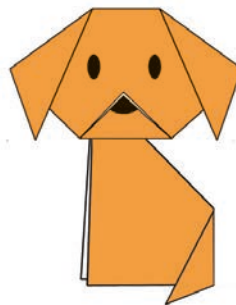
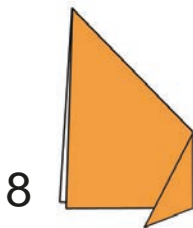
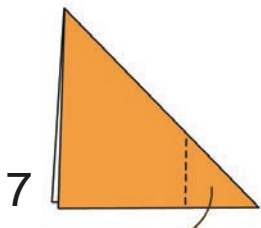
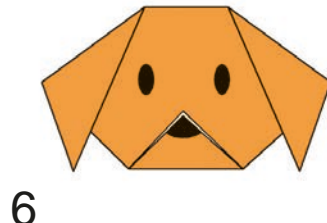
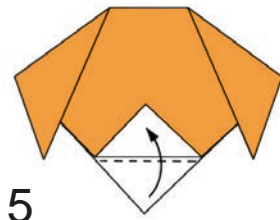
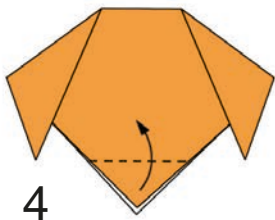
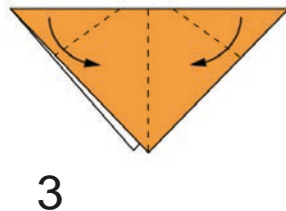
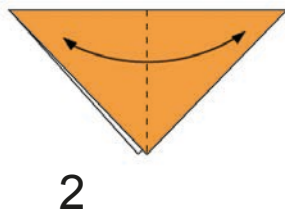
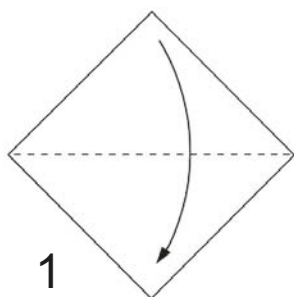



СОХТАНИ БОЗИЧАҶО БАРОИ СОЛИ НАВ

Соли Нав аз 1-уми январ оғоз мешавад. Ороишҳои идона сохта, синфхонаи худро оро диҳед.

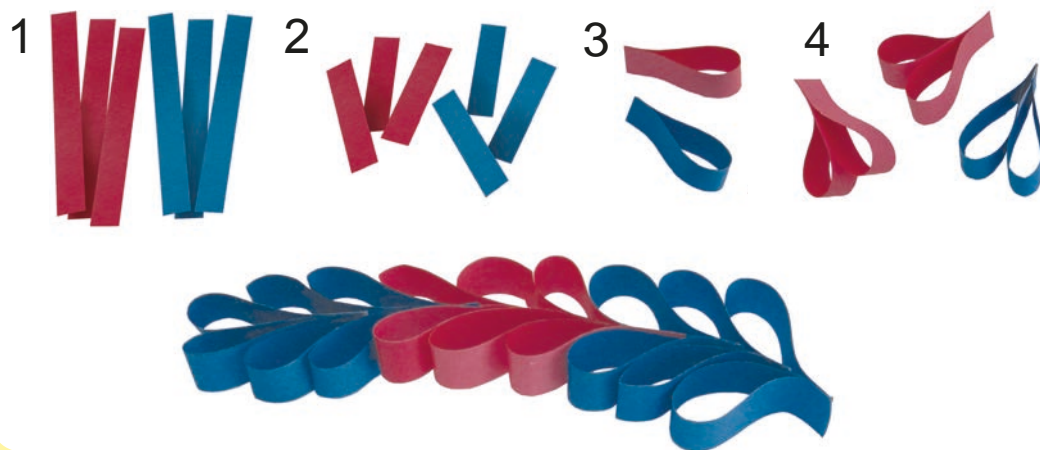
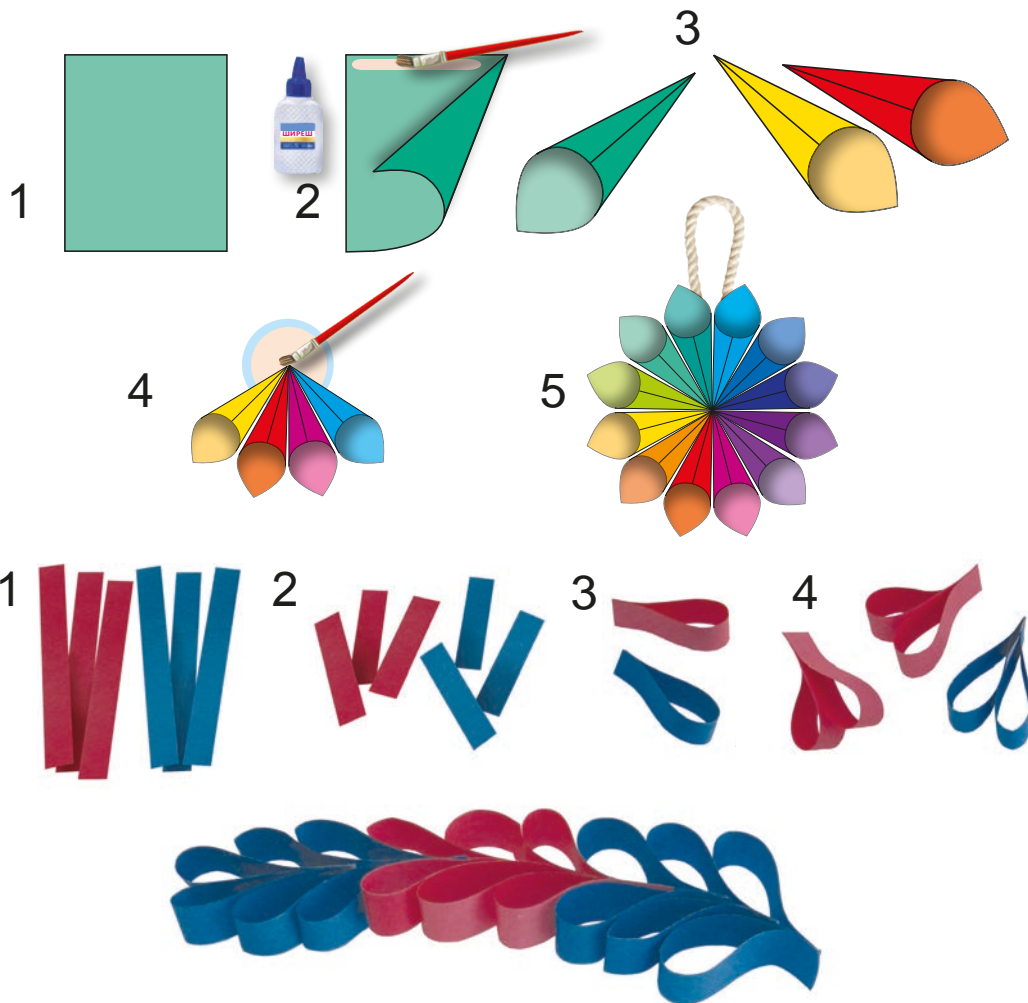



Дарси 16. СОХТАНИ НИҚОБ БАРОИ ИД

Сохтани ниқоби харгӯш

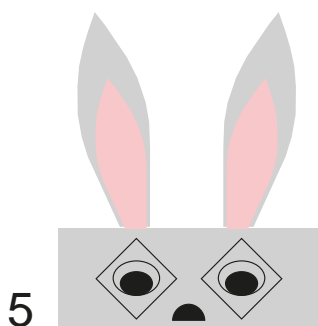
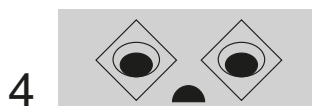
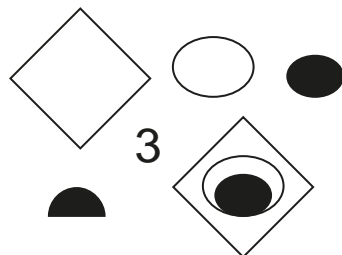
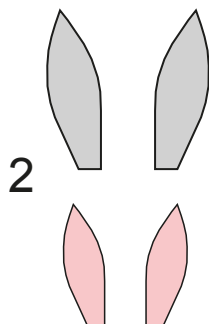
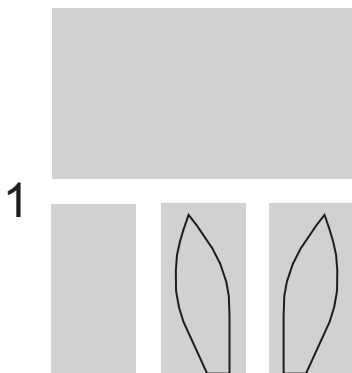
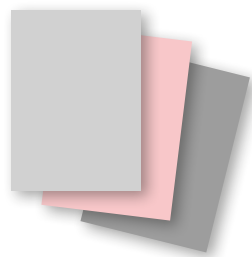



Сохтани ниқоби хирс

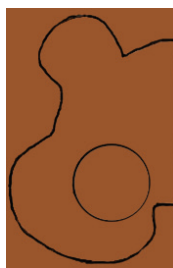

Коғазро дуқат карда, дар асоси андоза қисми сарро кашед.

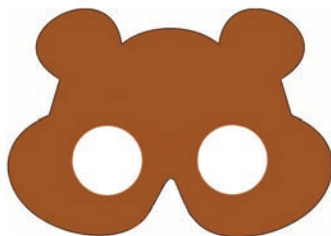

Аз рӯи хати кашидаатон буред. Байни онро кушода, бо қалам қош ва манаҳи онро кашед ва ранг кунед.





14-уми январ – „Рӯзи ҳимоятгарони Ватан“

Армия – ниғаҳбони ошоштагии ҳаёти мо. Аскарони пурқудрат ва бомадонати мо дар замин, об, ҳаво хизмат мекунанд.



Хизмати онҳо ба кадом техника алоқаманд аст?



Оё дар оилаи Шумо онҳое, ки хизмат мекунанд ва ё хизмат кардаанд ҳастанд? Барои онҳо тӯҳфа тайёр намоед.



Дарси 17. СОХТАНИ БОЗИЧАҶО АЗ КОҶАЗ

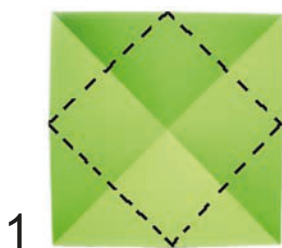

1

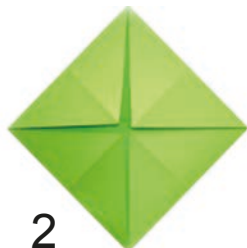

2

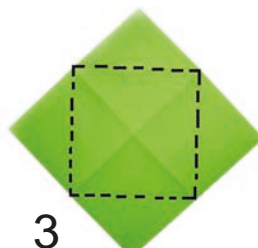

3



4



5

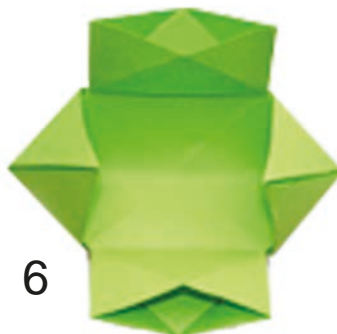

6



7



8

Аз заврақчаи сохтаатон Шумо чӣ гуна истифода бурданӣ ҳастед? Онро ба кӣ тақдим кардан мумкин аст?



Сохтани ҳавопаймо

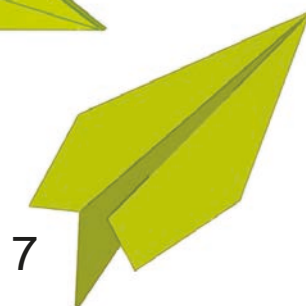
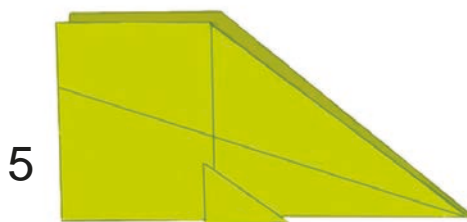
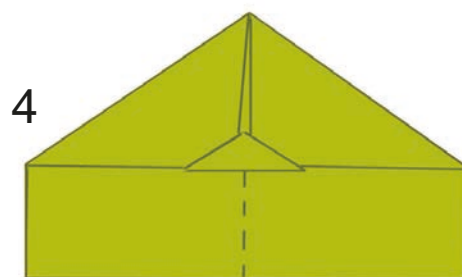
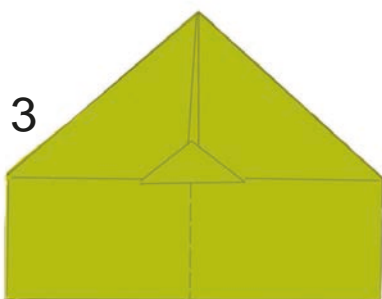
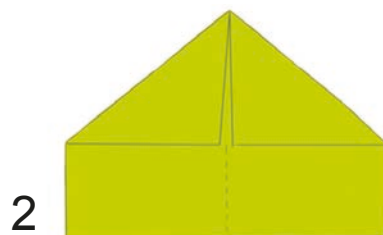

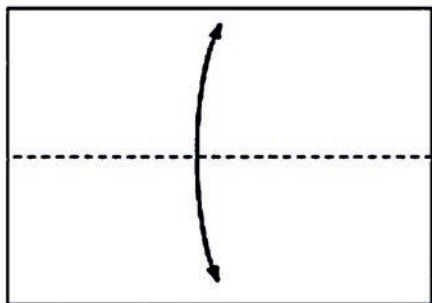

1

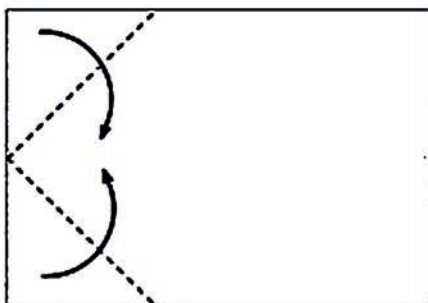

2

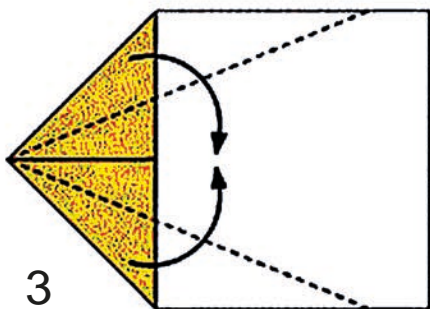

3

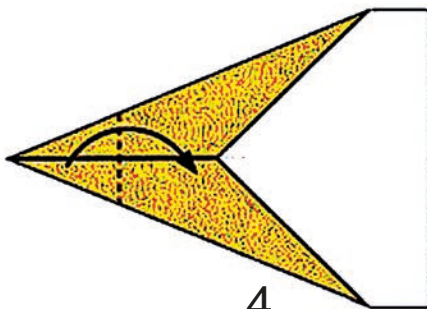

4

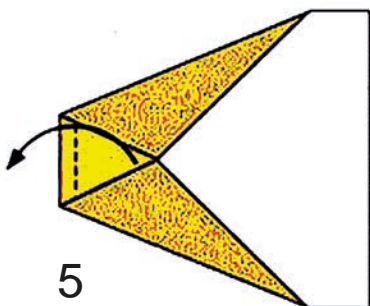

5

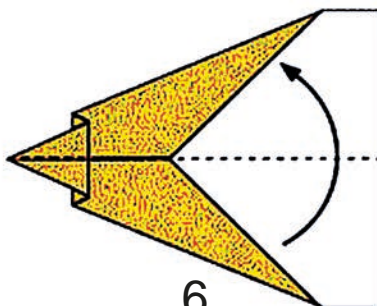

6

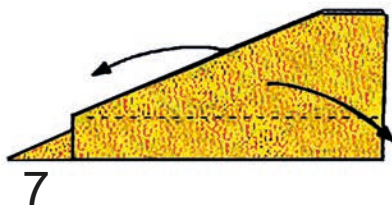

7

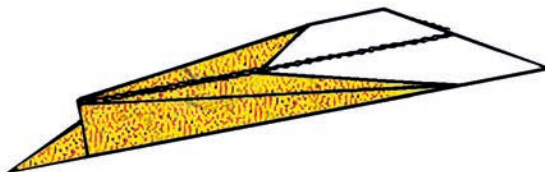



Дарси 18. СОХТАНИ МАНЗАРАИ ЗИМИСТОН БО ЁРИИ АПЛИКАТСИЯ

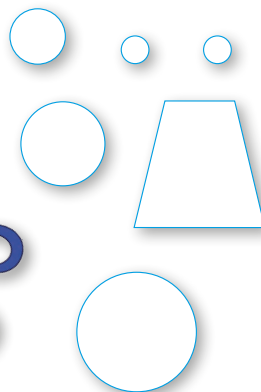
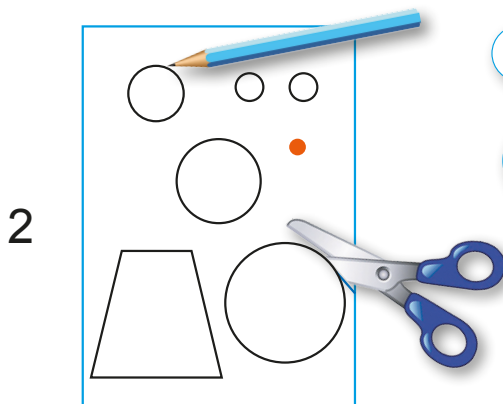
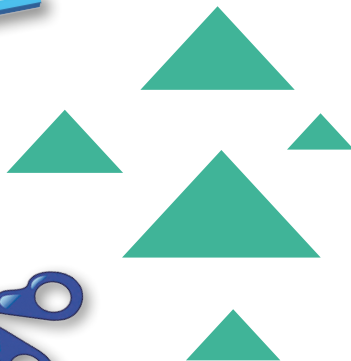
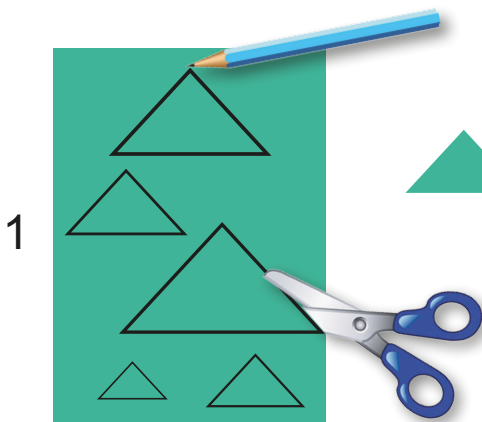

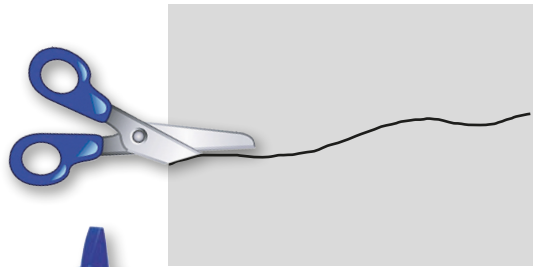
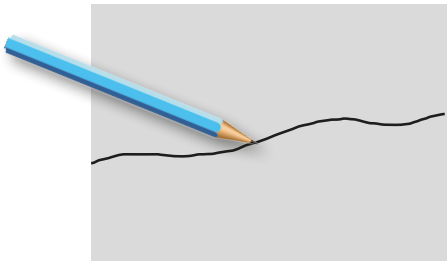

3

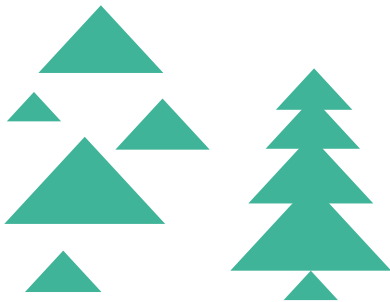

4

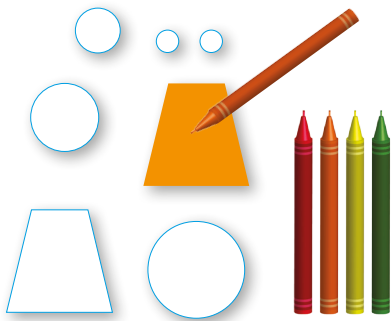

5



6





Дарси 19. АЗ РАСМҶОИ РАНГА ШАКЛИ ҲАЙВОНОТРО БУРИДА СОХТАН

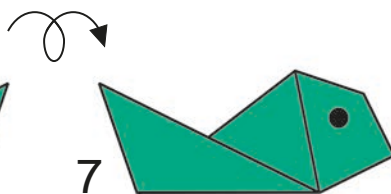
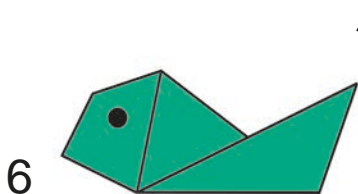
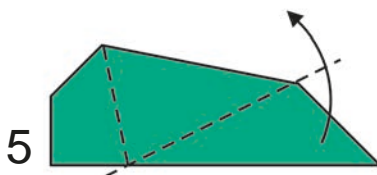
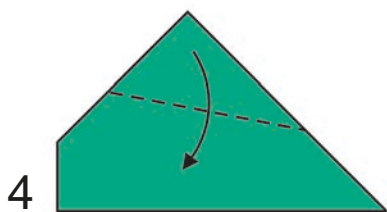
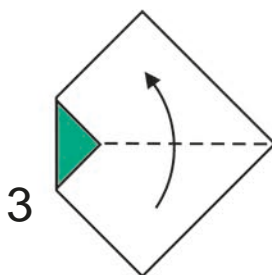
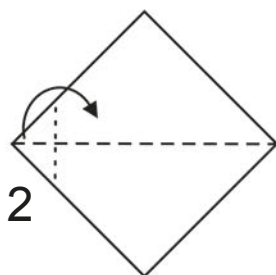
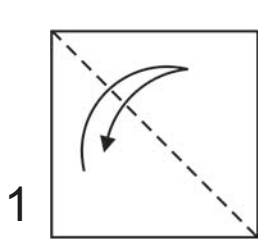



1

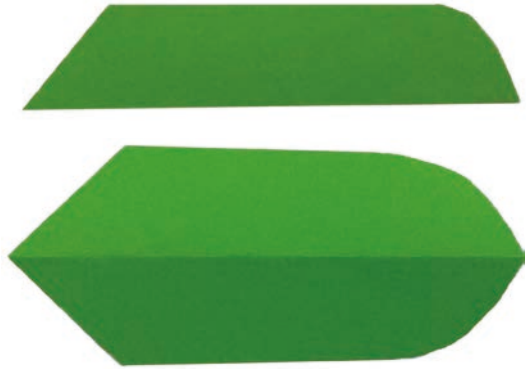

2



3



4

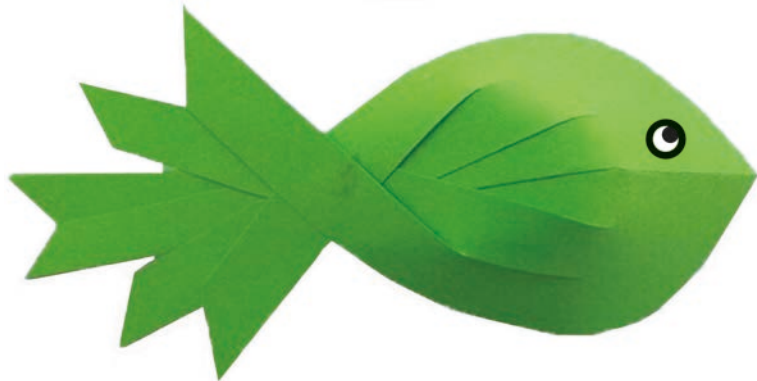



Дарси 20. АЗ КОҒАЗ ШАКЛИ РҶБОҲРО БУРИДАН ВА СОХТАН

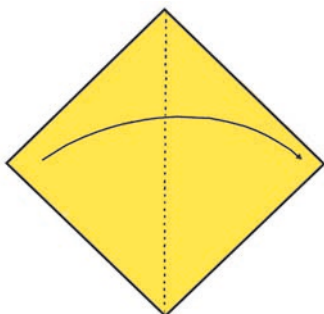

1

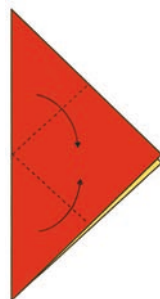

2

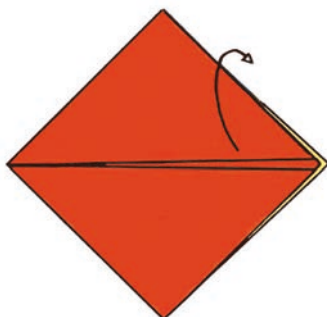

3

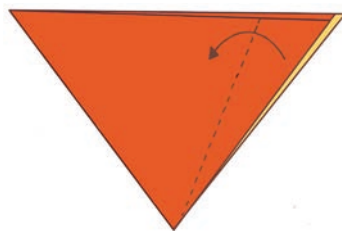

4

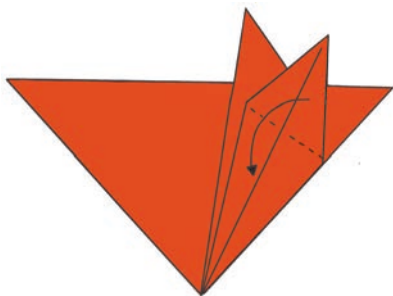

5

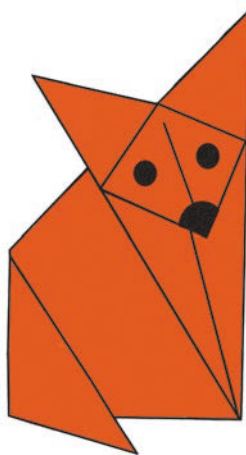



АЗ КОҒАЗ ШАКЛИ ГУРБАРО БУРИДАН ВА СОХТАН

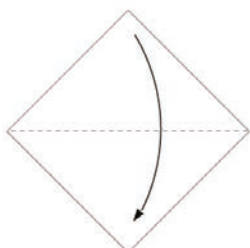

1

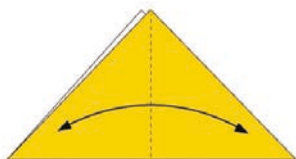

2

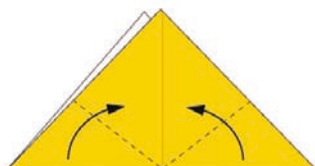

3

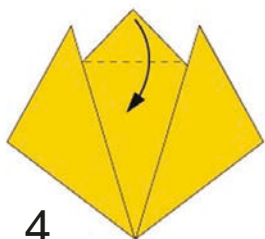

4

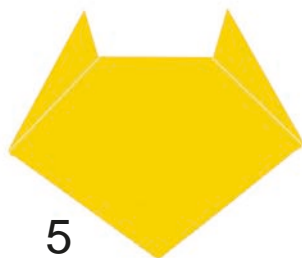

5

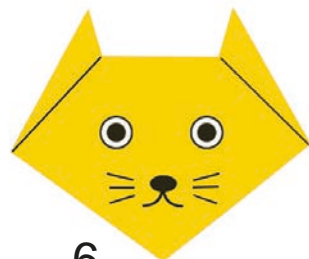

6



7



8



9



10

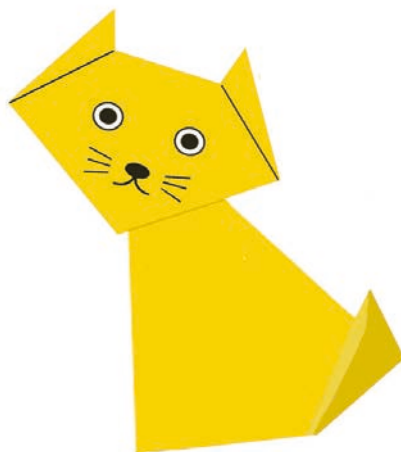



Дарси 21. МАФҶУМ ДАР БО- РАИ МОЗАИКА



Ҳиссаҷаҳои хурдакаки коғазро бо кадом тартиб ширеш кардан мумкин аст?

Зимистон чӣ гуна тасвир шудааст? Ба чӣ монанд аст?



Мозаика – нақш ва расме мебошад, ки аз ҳиссаҷаҳои майда-майда сохта шудаанд.

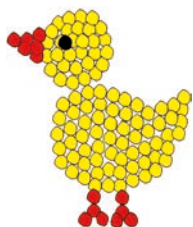

Фикр карда бинед, ки барои сохтани мозаика аз чӣ гуна коғаз истифода бурдан қулайтар аст? Коғази борик ё ғафс? Ҳиссаҷаҳои коғазро чӣ гуна часпонидан зарур аст?



Дарси 22. БО УСУЛИ МОЗАИКА ШАКЛИ САБЗАВОТРО СОХТАН

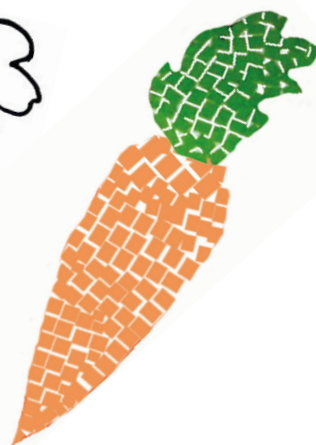
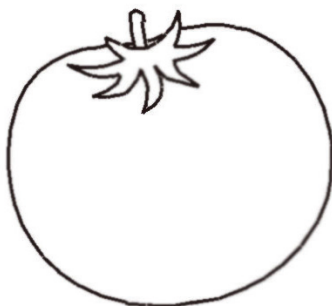
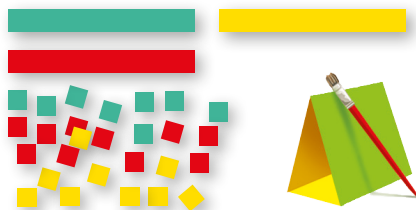

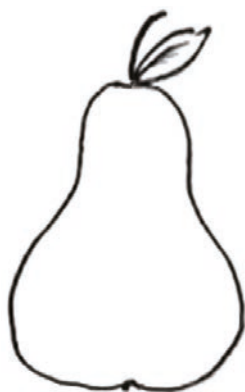
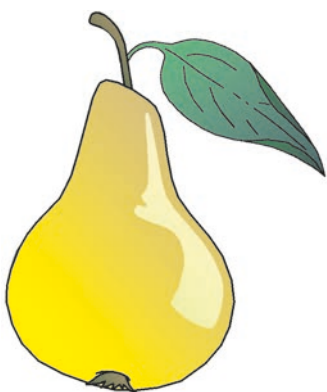
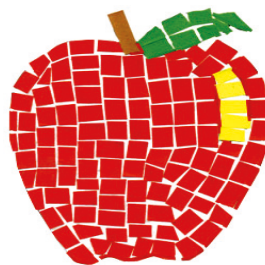

Коғази салфеткаро майда карда бурида, гулӯла кунед ва онро ба болои расми кашидаатон як хел часпонед.

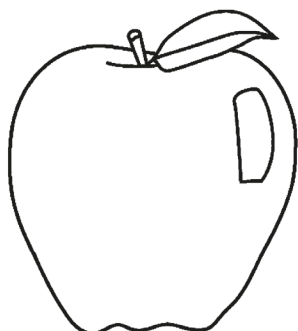



Дарси 23. КАСБИ ДИЗАЙНЕРӢ

Дизайн – фикр кардан, кашидан ва ба нақша гирифтан.

Дизайнер – рассоми лоиҳакаш.

Касби дизайнерӣ – рассоми мутахассиси соҳаи эстетикаи саноат.

Дизайнерӣ касби хеле шавқовар аст. Шахсоне, ки бо ин касб машғуланд, ҳар гуна чизҳои навро ихтироъ мекунанд. Инҳо ҷиҳозҳои хона, сару либос, асбобҳои техникӣ ва боз чандин чизҳои дигар шуданаш мумкин аст. Фарқи сохт ва ороиши чизҳоро мушоҳида кунед.





ТАЙЁР КАРДАНИ ТАБРИКНОМА БА ИДИ 8-УМИ МАРТ

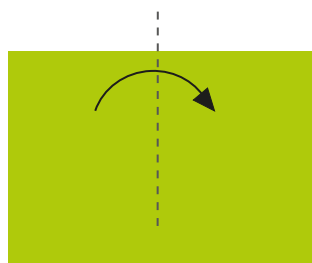

1

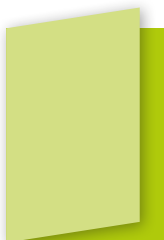

2

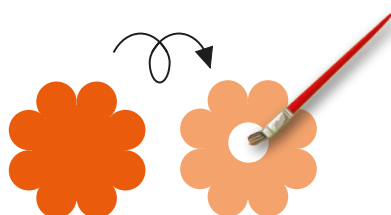

3

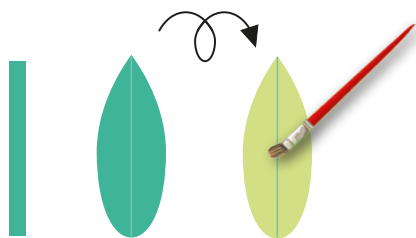

4



5

6

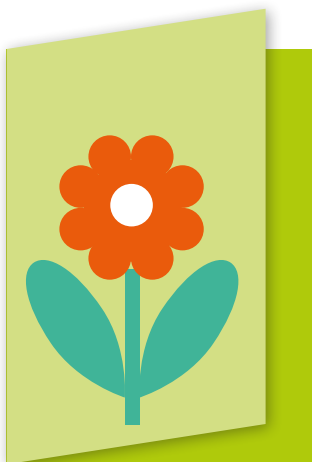

7





Дарси 24. ТАЙЁР КАРДАНИ ТАБРИКНОМА БА ИДИ НАВРӯЗ

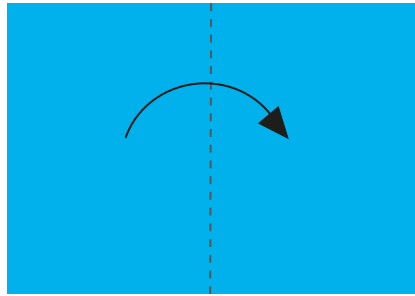

1

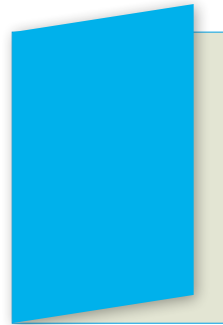

2

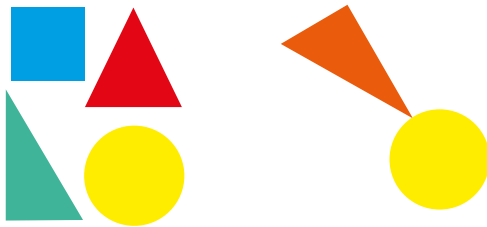

3

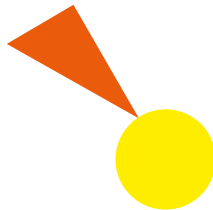

4

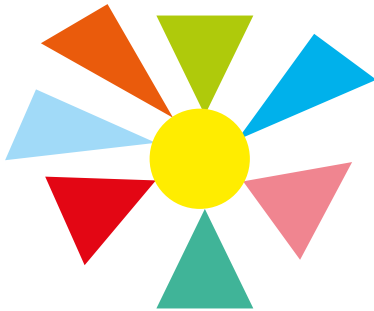

5



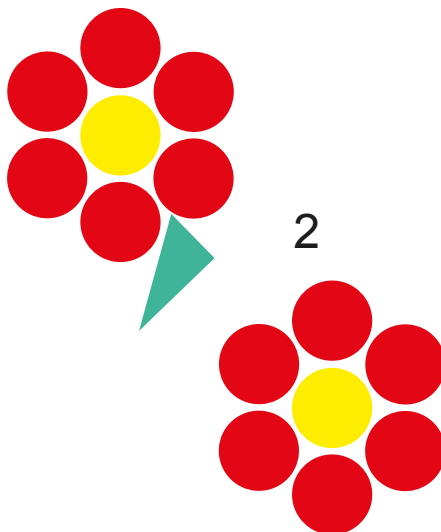
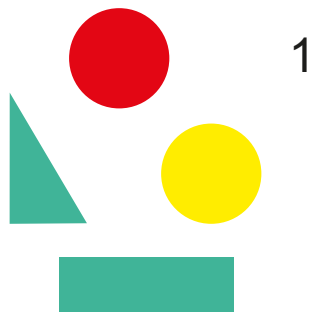



Дарси 25. УСУЛҶОИ БУРИДАНИ КОҶАЗҶОИ ШАКЛАШОН ГЕОМЕТРӢ

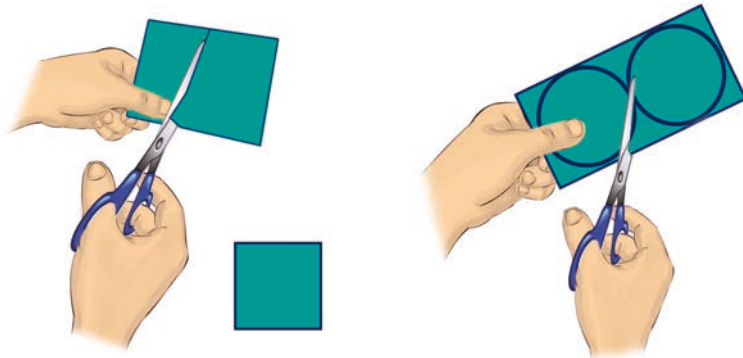
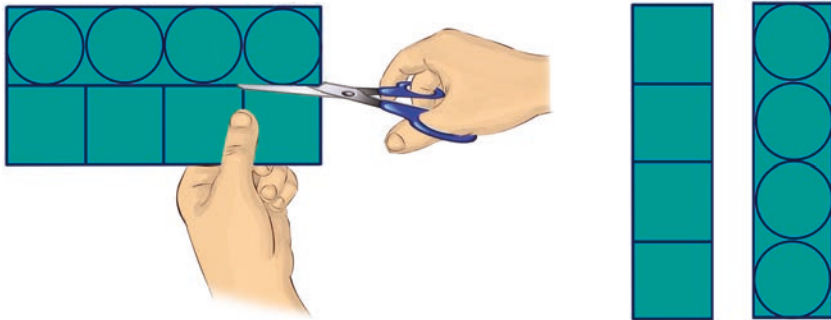
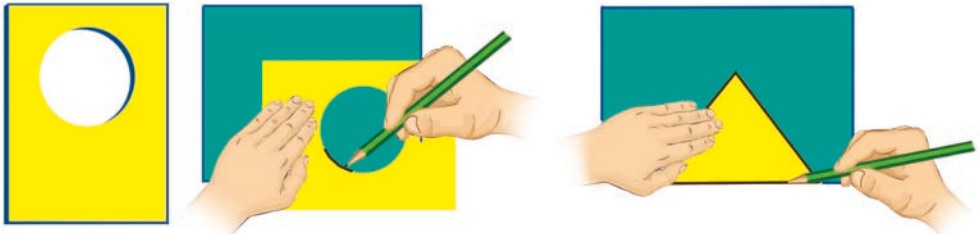



Дарси 26. СОХТАНИ СУРОБИ ҶАЙВОНОТ АЗ КОҶАЗҶОИ ШАКЛАШОН ГЕОМЕТРӢ

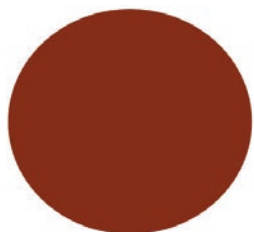

1



2



3

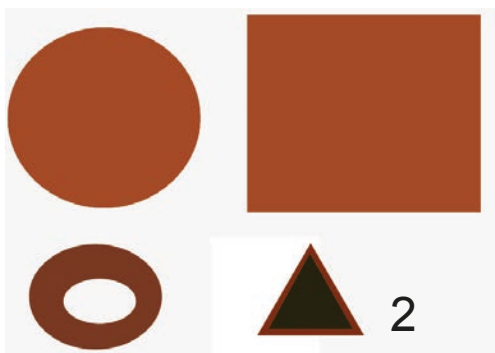
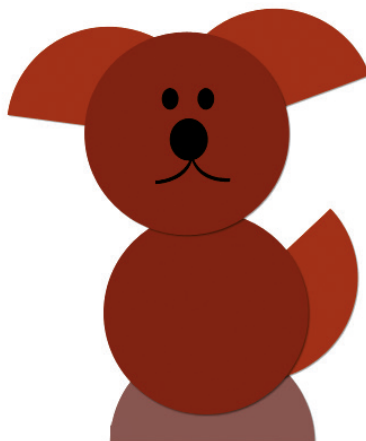

1



2

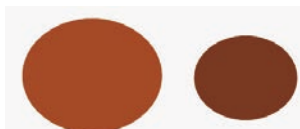

3





СОХТАНИ СУРОБИ ПАРРАНДАҶО АЗ КОҶАЗҶОИ ШАКЛАШОН ГЕОМЕТРӢ

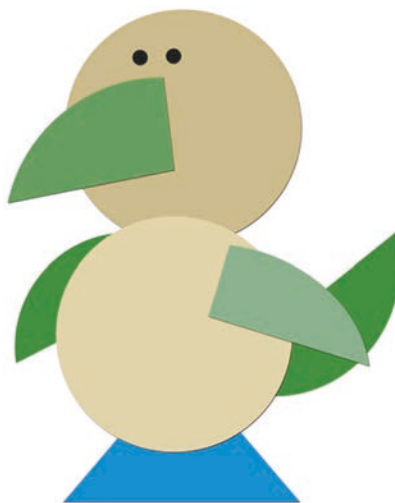
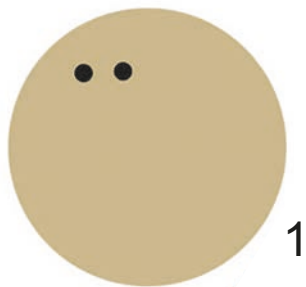



ТАСВИРИ ҲАЙВОНОТРО АЗ НАЗАР ГУЗАРОНЕД ВА СОХТА БИНЕД

Дар расм чӣ гуна ҳайвонот тасвир
ёфтааст? Барои сохтани онҳо шумо
аз кадом шакли қоғаз бояд истифода
баред?





Дарси 27. БУРИДАН ВА СОХ- ТАНИ СУРОБИ МАШИНА АЗ КОҶАЗҶОИ ШАКЛАШОН ГЕОМЕТРӢ

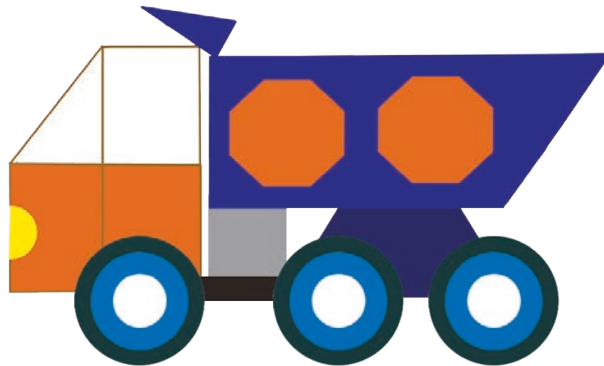

1



2



3

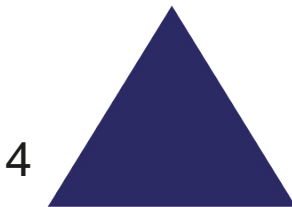

4



5



6



7



8



9



АЗ НАЗАР ГУЗАРОНЕД ВА СОХТА БИНЕД

Дар расм чӣ гуна машинаҳо тасвир
ёфтаанд? Аз рӯи ин расм мустақило-
на шакли машина созед.

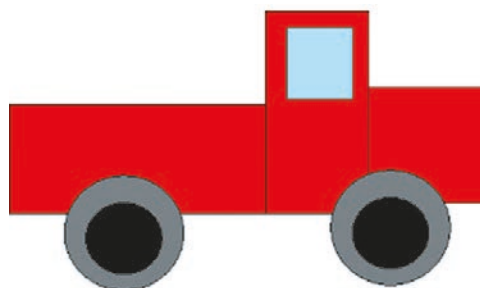



Дарси 28. СОХТАНИ СУРОБИ МЕВА ВА САБЗАВОТ АЗ ШАКЛҶОИ СИММЕТРӢ

Расмро бо диққат аз назар гузаронед. Баъди ба ду ҳисса қат кардани коғаз кадом кор ба иҷро мерасад?



Шакли себро бо роҳи ба ду ҳисса тақсим кардани коғаз тайёр кунед.

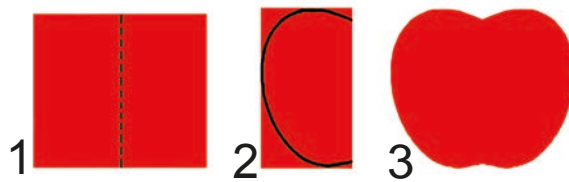

Аз коғазии дарозшакл суроби нокро созад.

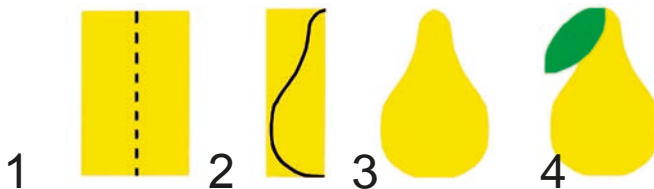

Коғазро қат кунед, шакли олучаро тайёр намоед.

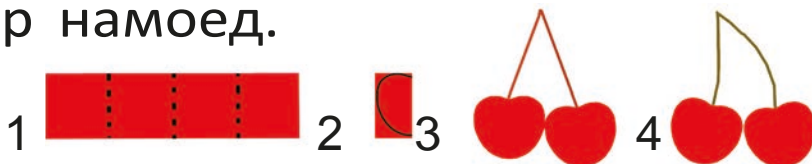

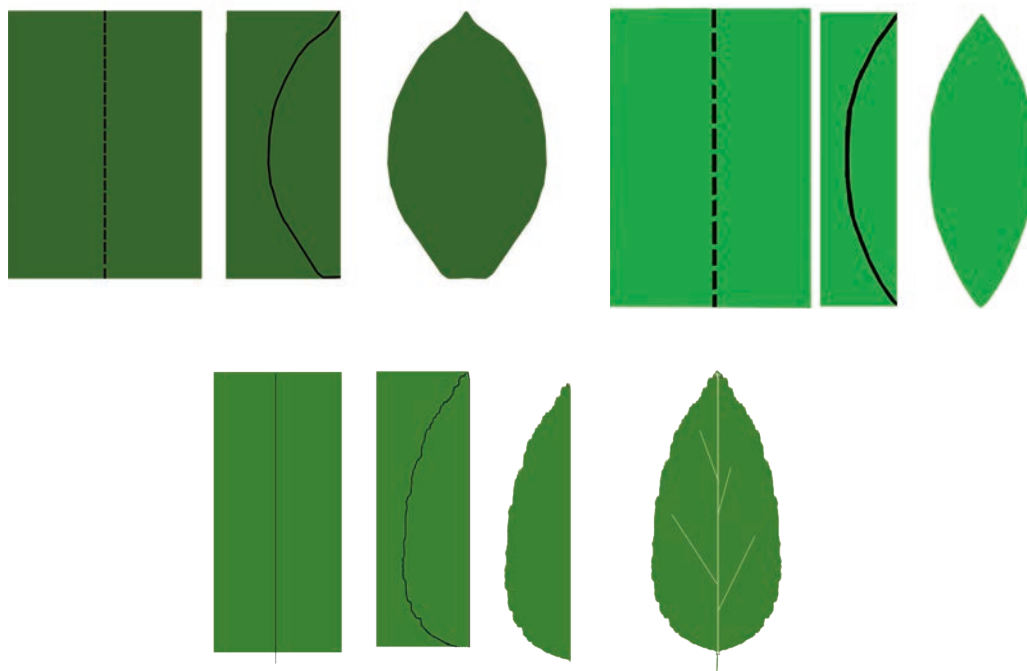

Меваҳои тайёркардаатонро ба лаъ-
лича андозед.

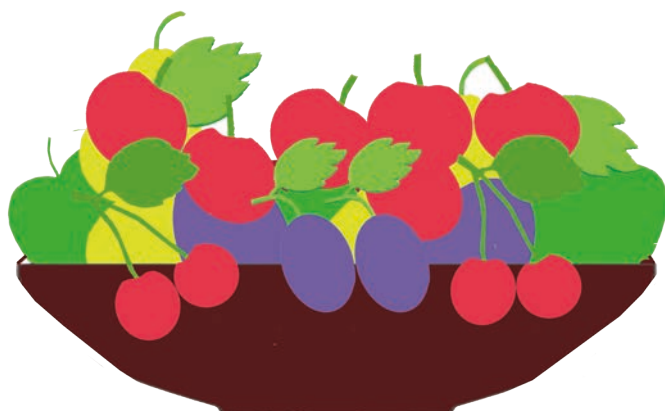



Дарси 29. КАСБИ БИНОКОРӢ

Дар кӯчаҳо шумо албатта хона, мактаб, кӯдакистон ва дӯконҳоро дидаед. Дар сохтмони ин биноҳо хиштрзон, андовачиён, дуредгарон, рангмолон ва соҳибони дигар касбу кор якҷоя меҳнат кардаанд.



Бигӯед, кӣ бо чӣ кор машғул аст?
Касби онҳо чӣ ном дорад?



СОХТАНИ МАКЕТИ ХОНАЧА

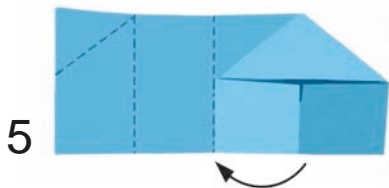
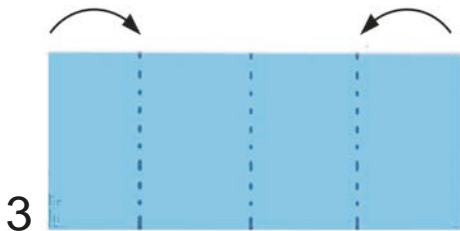
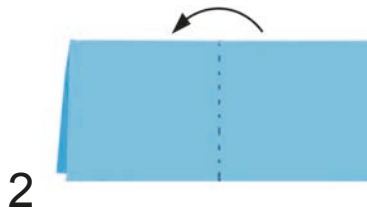
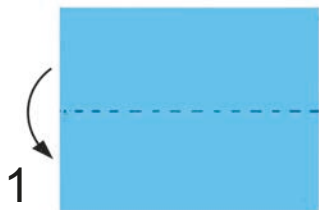



Мустақилона созед.



1



2



3



4



5



6

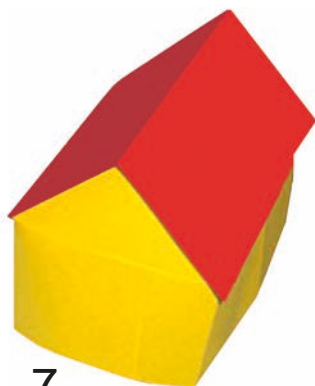

7



8



Дарси 30. АЗ КОҶАЗ БУРИДАН ВА СОХТАНИ „ГУЛҶОИ САБАДЧА“



1



2



3



4



5



6



7



1



2



3



4



5



6



7



8



Дарси 31. БО ЁРИИ ҚАТ КАР- ДАНИ КОҒАЗ СОҲТАНИ ШАКЛИ ПАРРАНДАҶО ВА ҲАЙВОНОТ

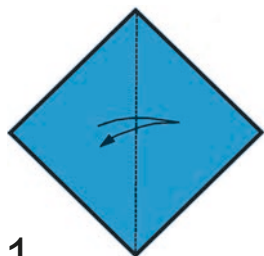

1

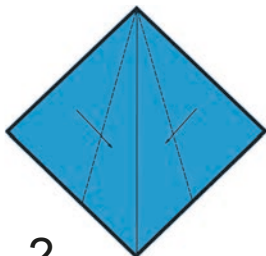

2

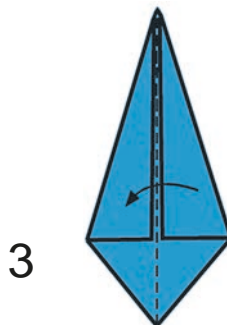

3



4



5

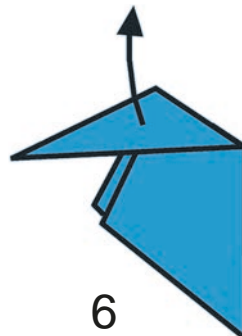

6

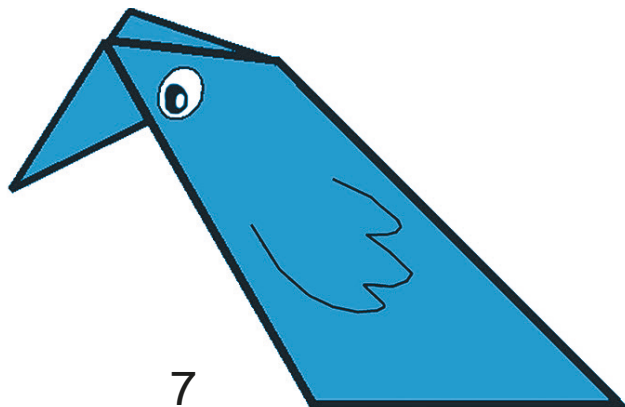

7



СУПОРИШҶОИ НАМУНАВӢ БАРОИ КОРИ НАЗОРАТӢ

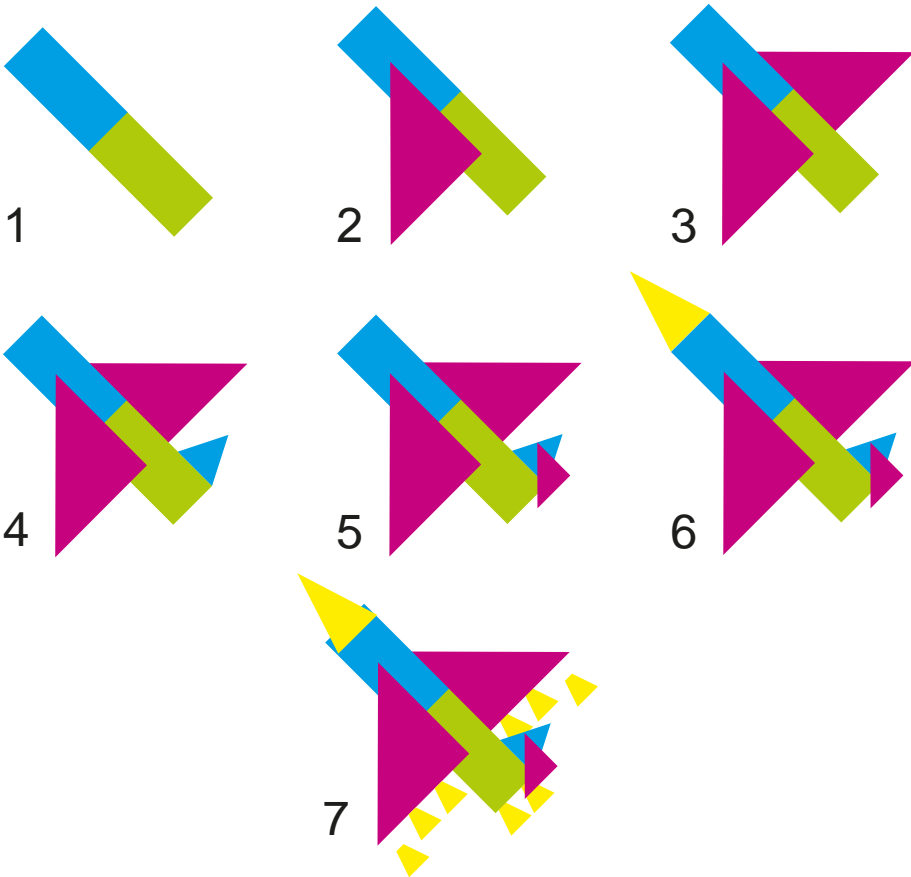
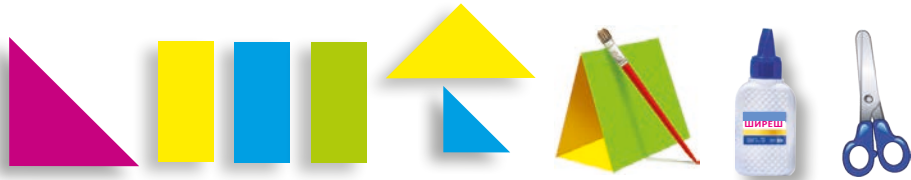

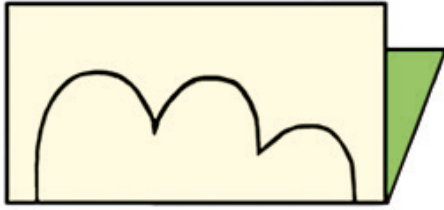

1

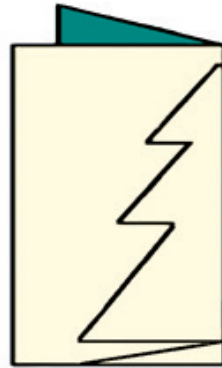

2

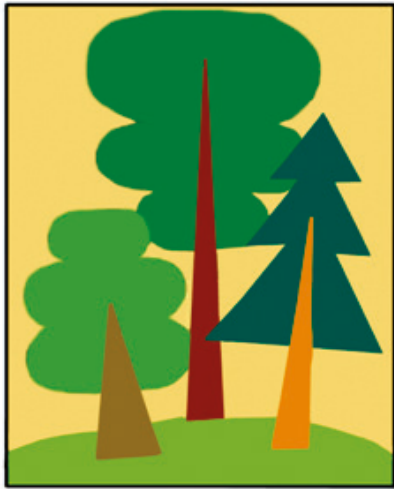

3

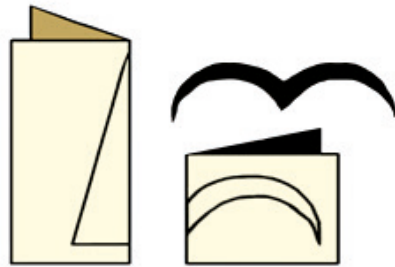

4



5

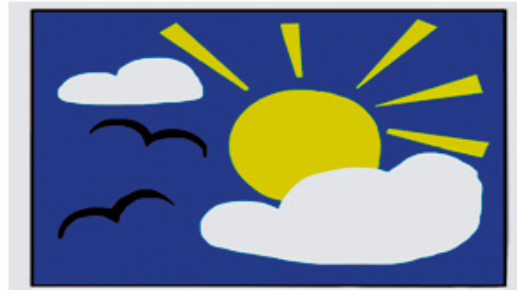

6

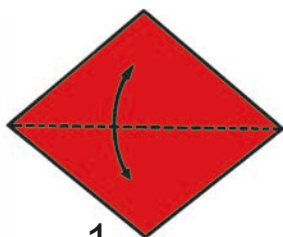

1



2



3

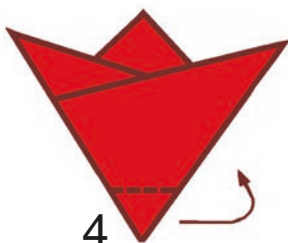

4



5



6

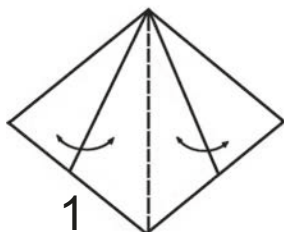

1



2



3



4

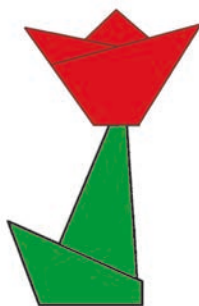

5





СОҶИБКАСБОН ҲИКОЯТ МЕКУНАНД

ОРНАМЕНТ ВА НАҚШ

Орнамент гуфта, яке аз элементҳои асосии асарҳои меъморӣ ва санъати амалиро меноманд. Он аз хат ва рангҳо иборат буда, барои рангубор, наққошӣ ва кандакории биноҳо ва чизҳо истифода мешавад.

Нақш гулҳое мебошад, ки бо он чизҳо, мебелҳо, хонаҳо оро дода мешаванд. Шахсе, ки хонаҳо, ҳар гуна чизҳо ва мебелҳоро нақшу нигор медиҳад, *наққош* ном дорад.

Дар Ўзбекистон санъати наққошӣ аз қадим ривоҷ ёфтааст. Ёдгориҳои мӯхташам то ба имрӯз ҷилои мафтункоронаи худро гум накардаанд. Агар ба таври умумӣ гӯем, нақш маъноии гулкориро дорад.



КОҒАЗ

Мактабро бе коғаз тасаввур кардан мушкил аст. Дафтар, китоб, журнали синф, рӯзнома ҳам аз коғаз тайёр карда мешаванд. Коғаз дар ҳаёти мо аҳамияти калон касб мекунад. Барои тайёр кардани як варақ коғаз меҳнати хеле зиёди одам сарф мешавад. Яке аз аввалинҳо шуда коғазро Тсау Луни хитой аз тӯри моҳидорӣ тайёр кардааст. Ин ихтироот на танҳо барои Хитой, бакли барои тамоми инсоният дорои аҳамияти бузург шудааст. Дар Ўзбекистон дар давраи ҳукмронии теуриён аҳамият ба истеҳсоли коғаз баланд шудааст. Бинобар ин, коғази Самарқанд дар байни хаттотони асрҳои миёнаи Шарқ қадри баланд дошта, қисми муайяни он ба хориҷ низ бароварда мешуд. Гарчанде технологияи истеҳсоли коғаз зиёда аз ҳазор сол боз дар таърих маълум бошад ҳам, он то ҳол ривож меёбад.



ҚАЙЧӢ

Қайчиеро, ки археологҳо аз харобаҳо пайдо кардаанд, яке аз қайчиҳои қадима буда, он 3-4 ҳазорсола аст. Ин қайчиро одамони қадим на барои истифодаи худ, балки барои бурида гирифтани пашми гӯсфандон истифода бурдаанд.

Ин қайчӣ бе ягон тағйирот зиёда аз ҳазор сол истифода шудааст.

Тахминан 1000 сол пеш, ҳунармандон ду кордро бо ҳам бо ёрии мех пайваст карда, бандашро ҳалқашакл карда, истифодаи қайчиро қулай кардаанд. Дертар, дар натиҷаи такмил додани сохти қайчӣ он ба воситаи кори сартарошон ва шифокорон табдил ёфтааст. Ҳар як усто қайчиҳои худро такмил додааст. Ҳатто қайчиҳои махсус низ пайдо шудаанд. Масалан, қайчиҳои боғбон, сартарош, дӯзанда, ҷарроҳ ва ғайра.



АППЛИКАТСИЯ

Аппликатсия аз калимаи лотинӣ гирифта шуда, маънои “пайваस्तкунӣ”-ро дорад. Он яке аз намудҳои санъати қадима мебошад. Аппликатсия аз коғаз, картон ё порчаҳои матоъ, гулҳои хушк ва баргҳо бо роҳи ши-решкунӣ ҳосил карда мешавад. Аппликатсияи ҳар як халқ бо шакл, ранг ва хусусиятҳои худ фарқ мекунад.



ОРИГАМИ

Оригами маънои “таҳ кардан ва қат кардан”-ро дорад. Дар технологияи оригами қайчиро истифода намебаранд. Санъати оригами дар Япония аз давраҳои қадимӣ илҳами шудааст. Дар асрҳои миёна он як ҳиссаи маданияти зодагони япониягӣро ташкил кардааст. Ҳоло технологияи оригами на танҳо дар Япония, балки дар тамоми дунё машғулияти дӯстдоштаи одамон гардидааст.

МУНДАРИҶА

Дарси 1. МАФҲУМ ДАР БОРАИ ФАННИ ТЕХНОЛОГИЯ.....	3
Дарси 2. СОХТАНИ МАНЗАРАИ “ТИРАМОҶИ ЗАРРИН”.....	8
Дарси 3. СОХТАНИ КОМПОЗИТСИЯИ НАҚШ АЗ БАРГҶО.....	11
Дарси 4. СОХТАНИ ШАКЛИ ПАРРАНДАҶО АЗ БАРГ.....	13
Дарси 5. СОХТАНИ ШАКЛИ ҶАЙВОНОТ АЗ БАРГ	15
Дарси 6. СОХТАНИ ПАРРАНДАҶО АЗ БАРГ.....	17
Дарси 7. СОХТАНИ ПАРРАНДАҶО АЗ МАВОДҶОИ ТАБИЙ ВА СУНЪЙ.....	18
Дарси 8. СОХТАНИ КОМПОЗИТСИЯ АЗ МАВОДҶОИ ТАБИЙ ВА СУНЪЙ.....	19
Дарси 9. ҶАМЪ КАРДАН ВА НИГОҶ ДОШТАНИ ТУХМЙ.....	20
Дарси 10. СОХТАНИ НАҚШ АЗ ТУХМЙ	21
Дарси 11. СОХТАНИ ШАКЛИ МОҶЙ	23
Дарси 12. СОХТАНИ ГУЛИ БОБУНА.....	24

Дарси 13. КОҒАЗ ВА НАМУДҶОИ ОН.....	27
Дарси 14. СОХТАНИ ХАТЧЎБ БАРОИ КИТОБ.....	32
Дарси 15. СОХТАНИ САГЧА АЗ КОҒАЗ.....	34
Дарси 16. СОХТАНИ НИҚОБ БАРОИ ИД	36
Дарси 17. СОХТАНИ БОЗИЧАҶО АЗ КОҒАЗ.....	39
ДАРСИ 18. СОХТАНИ МАНЗАРАИ ЗИМИСТОН БО ЁРИИ АПЛИКАТСИЯ.....	42
Дарси 19. АЗ РАСМҶОИ РАНГА ШАКЛИ ҶАЙВО- НОТРО БУРИДА СОХТАН	45
Дарси 20. АЗ КОҒАЗ ШАКЛИ РЎБОҶРО БУРИДАН ВА СОХТАН.....	47
Дарси 21. МАФҶУМ ДАР БОРАИ МОЗАИКА.....	49
Дарси 22. БО УСУЛИ МОЗАИКА ШАКЛИ САБЗА- ВОТРО СОХТАН.....	50
Дарси 23. КАСБИ ДИЗАЙНЕРӢ.....	52
Дарси 24. ТАЙЁР КАРДАНИ ТАБРИКНОМА БА ИДИ НАВРӢЗ	54
Дарси 25. УСУЛҶОИ БУРИДАНИ КОҒАЗҶОИ ШАКЛАШОН ГЕОМЕТРӢ.....	56

Дарси 26. СОХТАНИ СУРОБИ ҲАЙВОНОТ АЗ КО- ҒАЗҲОИ ШАКЛАШОН ГЕОМЕТРӢ.....	57
Дарси 27. БУРИДАН ВА СОХТАНИ СУРОБИ МАШИНА АЗ КОҒАЗҲОИ ШАКЛАШОН ГЕОМЕТРӢ.....	60
Дарси 28. СОХТАНИ СУРОБИ МЕВА ВА САБЗАВОТ АЗ ШАКЛҲОИ СИММЕТРӢ.....	62
Дарси 29. КАСБИ БИНОКОРӢ.....	64
Дарси 30. АЗ КОҒАЗ БУРИДАН ВА СОХТАНИ “ГУЛҲОИ САБАДЧА”.....	67
Дарси 31. БО ЁРИИ ҚАТ КАРДАНИ КОҒАЗ СОХ- ТАНИ ШАКЛИ ПАРРАНДАҲО ВА ҲАЙВОНОТ.....	69
СУПОРИШҲОИ НАМУНАВӢ БАРОИ КОРИ НАЗОРАТӢ.....	70
СОҲИБКАСБОН ҲИКОЯТ МЕКУНАНД.....	73

74.200.52
М 21

МАННОПОВА И.

Технология: Китоби дарси барои синфи 1 / И. Маннопова, Р.Мавлонова, Н.Ибрагимова. – Тошканд, ХЭТН: «O'qituvchi», 2019. – 80 саҳ.

ISBN 978-9943-22-346-2

УЎК: 373.3.016:331(075.2)

КБК 74.200.52

**Ilgizar Ahmadovna Mannopova
Rahima Abdurazzoqovna Mavlonova
Nazokat Ravshanxonovna Ibragimova**

TEKNOLOGIYA

**Ta'lim tojik tilida olib boriladigan maktablarning
1-sinfi uchun darslik**

Qayta ishlangan va to'ldirilgan
beshinchi nashri

*„O'qituvchi“ nashriyot-matbaa ijodiy uyi
Toshkent – 2019*

Мутарчим З. Баҳодурзода
Муҳаррир З. Файзуллоева
Муҳаррири ороиш ва рассом Шохрух Тоштурдиев
Дизайнер Олег Сава
Муҳаррири техникӣ Назокат Ниёзмұхамедова
Мусаҳҳаҳ Томирис Ёдгорова
Саҳифабанди компютери Дилноза Дўсматова

Литензияи нашриёт АИ № 012. 20.07.2018.

Аз оригинал-макет ба чоп 01.05.2019 иҷозат дода шуд. Андозаи 70x90¹/₁₆.

Кегли 18 шпондор. Бо усули офсет чоп шудааст. Коғази офсетӣ.

Ўзъи чопи шартӣ. 5,85. Ўзъи наشري ҳисобӣ. 5,0.

Адади нашр 7 767 нусха. Супориши №

Агенти ахборот ва коммуникатсияҳои оммавии назди Администратсияи

Президенти Республикаи Ўзбекистон

Хонаи эҷодии табуи наشري «O'qituvchi» .

Тошканд – 206, кўчаи Янгишаҳар, 1.

Шартномаи № 11-19